

(12) INTERNATIONAL APPLICATION PUBLISHED UNDER THE PATENT COOPERATION TREATY (PCT)

(19) World Intellectual Property Organization
International Bureau



(43) International Publication Date
14 November 2002 (14.11.2002)

PCT

(10) International Publication Number
WO 02/090713 A1

- (51) International Patent Classification⁷: E21B 43/10, 4/00
- (21) International Application Number: PCT/GB02/02171
- (22) International Filing Date: 9 May 2002 (09.05.2002)
- (25) Filing Language: English
- (26) Publication Language: English
- (30) Priority Data:
0111413.1 9 May 2001 (09.05.2001) GB
- (71) Applicant (for all designated States except US): e2 TECH LIMITED (GB/NL); Shell International B.V., P.O. Box 384, NL-2501 CJ The Hague (NL).
- (74) Agent: MURGITROYD & COMPANY; 165-169 Scotland Street, Glasgow G5 8PL (GB).
- (81) Designated States (national): AE, AG, AL, AM, AT, AU, AZ, BA, BB, BG, BR, BY, BZ, CA, CH, CN, CO, CR, CU, CZ, DE, DK, DM, DZ, EE, ES, FI, GB, GD, GE, GH, GM, HR, HU, ID, IL, IN, IS, JP, KE, KG, KP, KR, KZ, LC, LK, LR, LS, LT, LU, LV, MA, MD, MG, MK, MN, MW, MX, MZ, NO, NZ, PL, PT, RO, RU, SD, SE, SG, SI, SK, SL, TJ, TM, TR, TT, TZ, UA, UG, US, UZ, VN, YU, ZA, ZW.
- (84) Designated States (regional): ARIPO patent (GH, GM, KE, LS, MW, MZ, SD, SL, SZ, TZ, UG, ZM, ZW), Eurasian patent (AM, AZ, BY, KG, KZ, MD, RU, TJ, TM), European patent (AT, BE, CH, CY, DE, DK, ES, FI, FR, GB, GR, IE, IT, LU, MC, NL, PT, SE, TR), OAPI patent (BF, BJ, CF, CG, CI, CM, GA, GN, GQ, GW, ML, MR, NE, SN, TD, TG).

- (72) Inventors; and
- (75) Inventors/Applicants (for US only): BURGE, Philip, Michael [GB/GB]; Blackchambers, Westhill, Aberdeenshire AB32 7BU (GB). DOBSON, Andrew, Warnock [GB/GB]; 37 Kirk Crescent, North Cults, Aberdeen AB15 9RP (GB).

Published:
— with international search report

For two-letter codes and other abbreviations, refer to the "Guidance Notes on Codes and Abbreviations" appearing at the beginning of each regular issue of the PCT Gazette.

(54) Title: APPARATUS FOR AND METHOD OF RADIAL EXPANSION OF A TUBULAR MEMBER

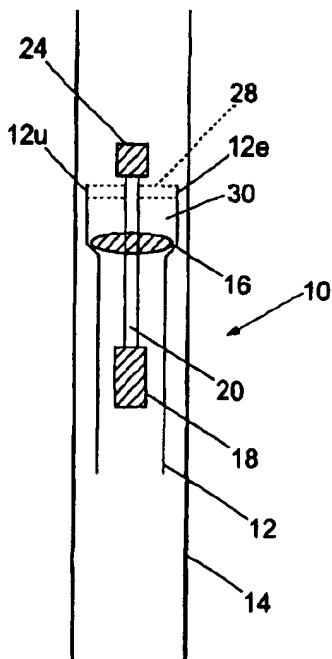

(57) Abstract: Apparatus for and method of radial expansion of a tubular member, with embodiments of the apparatus including an expander device (16), for example an expansion cone, which has a drive means (18) either attached to it or integral therewith. The drive means (18) can be a pump for example, where the pump creates a differential pressure across the expander device (16) to cause it to move.

1 "Apparatus for and Method of Radial Expansion of a
2 Tubular Member".

3

4 The present invention relates to apparatus and a
5 method particularly for the radial expansion of
6 tubular members.

7

8 Conventionally, tubular members can be expanded using
9 mechanical or other devices and methods where an
10 expander device (e.g. a cone) is pushed or pulled
11 through the tubular member to impart a radial plastic
12 and/or elastic deformation to the member to increase
13 its outer diameter (OD) and inner diameter (ID).

14 Alternatively, the cone may be forced through the
15 tubular member using hydraulic pressure. The tubular
16 member is optionally at least temporarily anchored
17 and the expander device is pushed or pulled through
18 the tubular member to impart the radial expansion
19 force.

20

21 There are a number of problems associated with so-
22 called "bottom-up" expansion. The portions of the

1 tubular member that have been expanded below the cone
2 may be in tension or compression during the expansion
3 process depending upon the location of the temporary
4 anchor (where used). Thus, during hydraulic
5 expansion of the tubular member for example, the
6 member is in a state of tension while also under
7 hydraulic pressure. Also, in the event of problems
8 with the expansion, the cone can potentially become
9 stuck as it is being pushed or pulled through the
10 expandable member, and this may require a fishing
11 operation to retrieve the stuck cone.

12
13 Additionally, conventional methods typically require
14 a rig so that the expander device can be pushed or
15 pulled through the tubular member using a wireline,
16 drill string, coiled tubing string or the like.

17
18 According to a first aspect of the present invention,
19 there is provided apparatus for radially expanding a
20 tubular member, the apparatus comprising an expander
21 device and a drive means for the expander device, the
22 drive means being capable of moving with the expander
23 device.

24
25 According to a second aspect of the present
26 invention, there is provided apparatus for radially
27 expanding a tubular member, the apparatus comprising
28 an expander device and a drive means for the expander
29 device, the drive means being capable of entering the
30 tubular member and moving the expander device.

1 According to a third aspect of the present invention,
2 there is provided a method of radially expanding a
3 tubular member, the method comprising the steps of
4 providing an expander device and a drive means,
5 locating the device and drive means in the tubular
6 member, and actuating the drive means to radially
7 expand the member.

8
9 The invention also provides apparatus for expanding a
10 tubular member, comprising an expander device having
11 an integral drive means for moving the device within
12 the tubular member.

13
14 The expander device is preferably an expansion cone.

15
16 The drive means typically comprises a pump. The pump
17 is typically attached to the expansion cone (e.g. by
18 a shaft or the like) but can be integral therewith.
19 For example, the expansion cone can be provided with
20 a longitudinal throughbore in which the pump can be
21 located.

22
23 The pump is typically used to create a differential
24 pressure across the expansion cone. The differential
25 pressure across the cone typically causes it to move
26 towards an area of lower pressure. The pump
27 typically draws fluid from one side of the expansion
28 cone to the other, thus causing the area of lower
29 pressure. The pump can be of any conventional type,
30 and can be, for example electric- or hydraulic-
31 driven. This has the advantage that only an electric

1 cable is required from the surface, and in certain
2 embodiments this is not required (e.g. where the pump
3 is hydraulically-driven). Where the pump is
4 electric-driven, no rig or the like is generally
5 required to push or pull the expander device.

6
7 A turbine can be used to provide power for the pump.
8 The turbine is typically fluid-driven (e.g.
9 hydraulically-driven).

10
11 The tubular member is optionally at least temporarily
12 anchored at an end thereof at least during radial
13 expansion of the member. A mechanical slip or packer
14 can be used as an anchor.

15
16 The tubular member is typically located in a second
17 conduit before radial expansion. The second conduit
18 may comprise a borehole, casing, liner or other
19 downhole tubular.

20
21 The tubular member can be any downhole tubular that
22 is capable of plastic and/or elastic deformation.
23 The tubular member is typically of steel or a steel
24 alloy (e.g. nickel alloy). The tubular member is
25 typically of a ductile material.

26
27 The tubular member can be a discrete length of
28 downhole tubular, or can be a string of downhole
29 tubulars that are coupled together (e.g. by welding,
30 screw threads etc).

31

1 The expansion cone can be of any conventional type.
2 The expansion cone is typically of a material that is
3 harder than the tubular member that is has to expand.
4 The expansion cone may be of ceramic, steel, steel
5 alloy, tungsten carbide or a combination of these
6 materials. It will be noted that only the portions
7 of the expansion cone that come into contact with the
8 tubular to be expanded need be coated or otherwise
9 covered with the harder material.

10

11 The method typically includes the additional step of
12 locating the tubular member in a second conduit.

13

14 The method optionally includes the additional step of
15 temporarily anchoring an end of the tubular member.

16

17 The step of actuating the drive means typically
18 comprises applying power to the pump. Alternatively,
19 the step of actuating the drive means may comprise
20 applying power to the turbine.

21

22 Embodiments of the present invention shall now be
23 described, by way of example only, with reference to
24 the accompanying drawings in which:-

25 Fig. 1 is a schematic representation of an
26 embodiment of apparatus that is being run into a
27 casing;

28 Fig. 2 is a schematic representation of the
29 apparatus of Fig. 1 in use;

30 Fig. 3a is a front elevation showing a first
31 configuration of a friction and/or sealing

1 material that can be applied to an outer surface
2 of a tubular;
3 Fig. 3b is an end elevation of the friction
4 and/or sealing material of Fig. 3a;
5 Fig. 3c is an enlarged view of a portion of the
6 material of Figs 3a and 3b showing a profiled
7 outer surface;
8 Fig. 4a is an front elevation of an alternative
9 configuration of a friction and/or sealing
10 material;
11 Fig. 4b is an end elevation of the friction
12 and/or sealing material of Fig. 4a; and
13 Fig. 5 shows an alternative embodiment of
14 apparatus for radial expansion of a tubular
15 member.

16
17 Referring to the drawings, Fig. 1 shows an exemplary
18 embodiment of apparatus 10 for the expansion of a
19 tubular member. Apparatus 10 as shown in Fig. 1 is
20 typically located within a portion of a downhole
21 tubular member 12 that is to be radially expanded
22 within a pre-installed portion of casing 14. The
23 tubular member 12 can be any downhole tubular such as
24 a casing, liner or the like and is typically of a
25 ductile material that is capable of plastic and/or
26 elastic deformation. The tubular 12 is typically of
27 steel or an alloy of steel (e.g. nickel alloy), but
28 other materials may be used. The pre-installed
29 casing 14 may be any conventional downhole tubular
30 such as casing, liner, drill pipe etc, and indeed

1 could be an open borehole that is to be cased and/or
2 lined.

3

4 Apparatus 10 includes an expansion cone 16 that is
5 typically located in a pre-expanded portion 12e of
6 the tubular 12 as the apparatus 10 is run in. The
7 expansion cone 16 has a pump 18 attached thereto e.g.
8 by a shaft 20. Expansion cone 16 may be of any
9 conventional type, but is typically of a material
10 that is harder than the material of the tubular
11 member that it has to expand. The cone 16 can be,
12 for example, of ceramic, steel, a steel alloy or
13 tungsten carbide etc. It may only be necessary to
14 coat or otherwise cover the portions of the cone 16
15 that come into contact with the tubular 12 during
16 expansion with a harder material.

17

18 Apparatus 10 is typically located within the tubular
19 12 at the surface. In particular, the expansion cone
20 16 is typically located within the pre-expanded
21 portion 12e of the tubular 12 at the surface.
22 Thereafter, the apparatus 10 and the tubular 12 are
23 run into the borehole to the position within casing
24 14 at which the tubular 12 is to be radially
25 expanded.

26

27 The pump 18 can be of any conventional type, e.g.
28 electrically- or hydraulically-driven. It will be
29 appreciated that the pump 18 may be incorporated
30 within the expansion cone 16 itself. For example,
31 and with reference to Fig. 5 showing an alternative

1 embodiment of apparatus 200, the cone 216 can be
2 provided with a throughbore 217 in which the pump 218
3 can be located. This would be particularly
4 advantageous as the apparatus 200 can be made smaller
5 and more compact.

6
7 The pump 18 is typically an electrical submersible
8 pump (ESP) that includes a pump driven by an electric
9 motor. Thus, an electrical cable (not shown) is
10 typically provided from the surface and coupled to
11 the motor of the pump 18 to drive it. Having the
12 pump 18 driven by electricity has advantages in that
13 only the electrical cable from the surface is
14 required. Thus, a rig or the like is not generally
15 required and the operation of the apparatus 10 can be
16 autonomous in that very little user intervention, if
17 any, is required.

18
19 The electrical cable can form part of an umbilical
20 cable or wireline that can be attached to apparatus
21 10. The umbilical or wireline has advantages in that
22 the apparatus 10 can be more easily retrieved from
23 the borehole once the tubular 12 has been radially
24 expanded, or if the apparatus 10 becomes stuck due to
25 a protrusion or restriction in its path.

26
27 Alternatively, the pump 18 can be driven by a turbine
28 24 that is typically located above the cone 16. The
29 turbine 24 is typically hydraulically-driven, and the
30 apparatus 10 is typically attached to a coiled tubing
31 string, drill string or the like through which fluids

1 may be pumped to drive the turbine 24. This would
2 generally require the use of a rig and may be useful
3 where a rig is already in place and available.

4
5 Although the turbine 24 has been shown in Figs 1 and
6 2, it will be appreciated that it will not be
7 required where the pump 18 is electrically-driven;
8 all that will be required is a power cable to the
9 motor of the pump 18.

10
11 The purpose of the pump 18 is to draw fluids from
12 below to above the cone 16 (as indicated by arrow 22
13 in Fig. 2), thereby creating a pressure differential
14 across the cone 16, which causes the cone 16 to move
15 downwards through the tubular 12, thus deforming and
16 radially expanding it. This is because the pump 18
17 creates an area of high pressure above the cone 16
18 and an area of lower pressure below it. Thus, the
19 cone 16 will be moved by the pressure differential
20 across it.

21
22 The pump 18 is typically mounted at a short distance
23 below the cone 16. The shaft 20 typically comprises
24 of two concentric conduits. An inner conduit (not
25 shown) would either house the drive shaft from the
26 turbine 24 to the pump 18; carry hydraulic fluid from
27 the surface (through a suitable string) to the
28 turbine where it is mounted below the cone 16 and
29 adjacent the pump 18; or to carry the electric cable
30 26 to take power to the pump 18. An outer conduit is
31 typically used as a conduit for the pressurised fluid

1 that is pumped from below the cone 16 to above it.
2 One or more ports would be provided in the cone 16 at
3 the termination of the outer conduit to allow fluid
4 to be pumped above the cone 16.

5
6 The radial expansion of the tubular 12 typically
7 causes an outer surface thereof to contact an inner
8 surface of the pre-installed casing 14, but this is
9 not essential. For example, the outer surface of the
10 tubular 12 can be provided with a friction and/or
11 sealing material to provide an anchor and seal in the
12 annulus between the tubular 12 and the casing 14.
13 Alternatively, spacers may be located in the annulus
14 or cement used.

15
16 Use of the terms "above", "below", "upward" and
17 "downward" herein are used with respect to the
18 orientation of the apparatus shown in Figs 1 and 2.
19 These terms should be construed accordingly where the
20 apparatus is used in a lateral or deviated borehole.
21 The terms "below" and "downward" generally refer to
22 locations or directions that are nearer the formation
23 or payzone.

24
25 It will be appreciated that the apparatus 10 can be
26 used to expand the tubular 12 from the bottom-up by
27 reversing the direction of the apparatus 10 (e.g.
28 turning it upside down with respect to the
29 orientation of the apparatus in Fig. 1). However, it
30 is advantageous to use the apparatus 10 to expand the
31 tubular 12 from the top-down because the apparatus 10

1 can be retrieved easily and more quickly should its
2 travel be arrested due to a protrusion or restriction
3 in its path. This is because the portions of the
4 tubular 12 that have not been expanded when the
5 apparatus 10 becomes stuck will be below the
6 apparatus 10, and thus it can be pulled out of the
7 borehole relatively easily.

8

9 The cone 16 is typically located in the pre-expanded
10 portion 12e as tubular 12 is lowered into the
11 borehole, as shown in Fig. 1.

12

13 The cone 16 can be attached to a drill string, coiled
14 tubing string or the like, but this is not generally
15 required, as the pump 18 can be electric so that only
16 an electrical cable to the pump 18 is required.
17 Alternatively, the pump 18 may be hydraulically-
18 driven and this generally requires a drill string or
19 coiled tubing string for example through which fluids
20 may be pumped (e.g. from the surface) to drive the
21 pump 18 downhole.

22

23 The expansion process can therefore be autonomous
24 where an electric pump and cable are used; that is
25 once the pump 18 is actuated, there need be no
26 further user intervention until the apparatus 10 is
27 to be retrieved from the borehole (e.g. using a
28 conventional fishing operation). However, a wireline
29 or umbilical may be attached to the apparatus 10 to
30 facilitate easy retrieval from the borehole should it
31 become stuck, or once it has expanded the tubular 12.

1
2 Also, where the pump 18 is electrically-driven, no
3 rig is required because a wireline, coiled tubing
4 string or drill string is not required to propel the
5 apparatus 10; only an electrical cable is required.
6 This has significant advantages because the apparatus
7 10 can be used to repair damaged or washed-out liner
8 by overlaying another liner on top and radially
9 expanding this into place so that it straddles the
10 damaged portion, without the need to use a rig. The
11 apparatus 10 can also be used to install new casing,
12 liner etc without the need for a rig.

13
14 The tubular 12 is optionally at least temporarily
15 anchored at an end thereof during the expansion
16 process. The tubular 12 can be anchored using any
17 conventional means, such as a mechanical slip or a
18 packer for example. Where the anchor is located at a
19 lower end of the tubular 12, and expansion begins at
20 the lower end, the tubular 12 will generally be in
21 tension during the expansion process. This is also
22 the case where the tubular 12 is anchored at the top
23 and the expansion process is top-down. Where the
24 anchor is located at an upper end of the tubular 12
25 and the expansion process is bottom-up, the tubular
26 12 will generally be in compression during the
27 expansion process. Similarly, if the tubular 12 is
28 anchored at a lower end and the expansion process is
29 top-down, the tubular 12 will generally be in
30 compression during expansion.

31

1 In certain embodiments, the apparatus 10 can include
2 an inflatable device 28 (e.g. a packer) that is
3 shown in phantom in Figs 1 and 2. The inflatable
4 device 28 can be located in the pre-expanded portion
5 12e and then inflated at the required depth to
6 provide a temporary anchor for the tubular 12 to the
7 pre-installed casing 14. The inflatable device 28
8 can be releasably attached to the apparatus 10 so
9 that once it has formed an anchor, it can be detached
10 from the apparatus 10 and left *in situ* to be
11 collected once the expansion process is completed
12 (e.g. as the apparatus 10 is pulled out of hole).
13 The inflation of the inflatable device 28 causes the
14 pre-expanded portion 12e to be expanded further so
15 that a portion thereof contacts the casing 14.
16 Alternatively, or additionally, an outer surface of
17 the tubular 12 can be provided with a friction and/or
18 sealing material (e.g. rubber) that engages the
19 casing 14 to provide a seal there between, and also
20 to provide an anchor point for the subsequent
21 expansion of the tubular 12.

22
23 The inflatable device 28 can also be used to provide
24 a fluid chamber 30 in which fluid that is pumped from
25 below the cone 16 can collect. The build up of
26 pressure in the chamber 30 and the lower pressure
27 below the cone 16 causes the cone 16 to move
28 downwards and thus expand the tubular. The
29 inflatable device 28 provides a local seal for the
30 fluid pressure above the cone 16 and would generally
31 only be required until a sufficient portion of the

1 tubular 12 has been expanded to provide a seal. The
2 seal can be created by a metal-to-metal contact
3 between the tubular 12 and the casing 14, but a
4 friction and/or sealing material can be provided on
5 the outer surface of the tubular 12 so that a seal is
6 created when the tubular 12 is expanded. Once the
7 tubular 12 has been expanded sufficiently to provide
8 a seal, the inflatable device 28 is generally no
9 longer required and can be deflated.

10
11 Where the inflatable device 28 is located within the
12 pre-expanded portion 12e, as shown in Fig. 1, the
13 inflatable device 28 can be used to expand the pre-
14 expanded portion 12e (or portions thereof), as
15 described above. The pre-expanded portion 12e can be
16 provided with the friction and/or sealing material so
17 that the material is energised upon inflation of the
18 inflatable device to provide a local seal for the
19 fluid pressure.

20
21 The inflatable device 28 can be telescopically
22 attached to the expansion cone 16, and may be of any
23 suitable configuration, but is typically a device
24 that has an inflatable annular balloon-type portion
25 that is mounted on an annular ring. The annular ring
26 allows a string, wireline or the like to be passed
27 through the inflatable device 28 as required, or in
28 the embodiment shown, allows the shaft 20 and the
29 electrical cable to the pump 18 (if required) to pass
30 therethrough.

31

1 Where the expansion cone 16 is telescopically coupled
2 to the inflatable device 28 using a telescopic
3 coupling, the coupling typically comprises one or
4 more telescopically coupled members that are attached
5 to the inflatable device 28. As the expansion cone
6 28 moves downwards, the telescopic coupling extends a
7 certain distance, say 10 feet (approximately 3
8 metres), at which point the telescopic member(s) are
9 fully extended. At this point, the inflatable
10 balloon-type portion of the inflatable device can be
11 automatically deflated and further downward movement
12 of the expansion cone 16 causes the inflatable device
13 28 also to move downward therewith.

14
15 It should be noted that the inflatable device 28 is
16 no longer required to anchor the tubular 12 to the
17 casing 14 as the expanded portion of tubular 12
18 secures it to the casing 14. A friction and/or
19 sealing material (e.g. material 100, 122 as described
20 below) can be used to enhance the grip of the tubular
21 12 on the casing 14 in use, and can also provide a
22 seal in an annulus created between the tubular 12 and
23 the casing 14.

24
25 Referring to Figs 3a to 3c, there is shown an
26 exemplary configuration of a friction and/or sealing
27 material 100 that can be applied to the outer surface
28 of the tubular 12. The material 100 typically
29 comprises first and second bands 102, 104 that are
30 axially spaced-apart along a longitudinal axis of the
31 tubular 12. The first and second bands 102, 104 are

1 typically axially spaced by some distance, for
2 example 5 inches (approximately 127mm).

3
4 The first and second bands 102, 104 are preferably
5 annular bands that extend circumferentially around
6 the tubular 12, although this configuration is not
7 essential. The first and second bands 102, 104
8 typically comprise 1 inch wide (approximately 25.4mm)
9 bands of a first type of rubber. The friction and/or
10 sealing material 100 need not extend around the full
11 circumference of the tubular 12.

12
13 Located between the first and second bands 102, 104
14 is a third band 106 of a second type of rubber. The
15 third band 106 preferably extends between the first
16 and second bands 102, 104 and is thus typically 3
17 inches (approximately 76mm) wide.

18
19 The first and second bands 102, 104 are typically of
20 a first depth. The third band 106 is typically of a
21 second depth. The first depth is optionally larger
22 than the second depth, although they can be the same,
23 as shown in Fig. 3a. The first and second bands 102,
24 104 may protrude further from the surface of the
25 tubular 12 than the third band 106, although this is
26 not essential.

27
28 The first type of rubber (i.e. first and second bands
29 102, 104) is preferably of a harder consistency than
30 the second type of rubber (i.e. third band 106). The
31 first type of rubber is typically 90 durometer

1 rubber, whereas the second type of rubber is
2 typically 60 durometer rubber. Durometer is a
3 conventional hardness scale for rubber.

4
5 The particular properties of the rubber may be of any
6 suitable type and the hardnesses quoted are
7 exemplary only. It should also be noted that the
8 relative dimensions and spacings of the first, second
9 and third bands 102, 104, 106 are exemplary only and
10 may be of any suitable dimensions and spacing.

11
12 As can be seen from Fig. 3c in particular, an outer
13 face 106s of the third band 106 can be profiled. The
14 outer face 106s is ribbed to enhance the grip of the
15 third band 106 on an inner face 12i of the casing 12.
16 It will be appreciated that an outer surface on the
17 first and second bands 102, 104 may also be profiled
18 (e.g. ribbed). The material of the third band 106
19 can deform into the spaces between the ribs when it
20 is compressed during expansion.

21
22 The two outer bands 102, 104 being of a harder rubber
23 provide a relatively high temperature seal and a
24 back-up seal to the relatively softer rubber of the
25 third band 106. The third band 106 typically
26 provides a lower temperature seal.

27
28 A number of portions 108 are provided in the first
29 and second bands 102, 104. The portions 108 are of a
30 reduced thickness in the lateral direction. The
31 rubber of the first and second bands 102, 104 is

1 relatively hard and thus tends not to stretch. The
2 portions 108 of reduced thickness allow the material
3 to stretch at these portions without breaking.

4

5 An alternative embodiment of a friction and/or
6 sealing material 122 that can be applied to the outer
7 surface of the tubular 12 is best shown in Figs 4a
8 and 4b. The friction and/or sealing material 122 is
9 in the form of a zigzag. In this embodiment, the
10 friction and/or sealing material 122 comprises a
11 single (preferably annular) band of rubber that is,
12 for example, of 90 durometers hardness and is about
13 2.5 inches (approximately 28mm) wide by around 0.12
14 inches (approximately 3mm) deep.

15

16 To provide a zigzag pattern and hence increase the
17 strength of the grip and/or seal that the material
18 122 provides in use, a number of slots 124a, 124b
19 (e.g. 20) are milled into the band of rubber. The
20 slots 124a, 124b are typically in the order of 0.2
21 inches (approximately 5mm) wide by around 2 inches
22 (approximately 50mm) long.

23

24 To create the zigzag pattern, the slots 124a are
25 milled at around 20 circumferentially spaced-apart
26 locations, with around 18° between each along one
27 edge 122a of the band. The process is then repeated
28 by milling another 20 slots 124b on the other side
29 122b of the band, the slots 124b on side 122b being
30 circumferentially offset by 9° from the slots 124a on
31 the other side 122a.

1
2 As an alternative to having the inflatable device 28
3 telescopically coupled to the expansion cone, the
4 tubular 12 can be provided with an expandable portion
5 of casing or liner (not shown). The expandable
6 portion may be located at an upper end 12u of the
7 tubular 12 or may be integral therewith.

8
9 The inflatable device 28 is inflated to expand the
10 inflatable annular balloon-type portion. As the
11 balloon-type portion expands, the expandable portion
12 of the tubular 12 also expands. The contact between
13 the expandable portion and the casing 14 provides an
14 anchor point and/or a seal between the tubular 12 (to
15 which the expandable portion is attached or integral
16 therewith) and the casing 14. Thus, the contact
17 provides a seal for the fluid pressure that is used
18 to force the expansion cone 16 through the tubular
19 12.

20
21 As the expansion cone 16 moves downward through the
22 tubular 12 to radially expand it, the movement of the
23 cone 16 is stopped after a predetermined time or
24 distance, at which point the cone 16 can be retracted
25 until a coupling between the expansion cone 16 and
26 the inflatable device 28 latches. At this time, the
27 inflatable annular balloon-type portion is
28 automatically deflated and the apparatus 10 is
29 actuated and begins to move downward. Movement of
30 the expansion cone 16 causes the inflatable device 28
31 also to move downward. It should be noted that the

1 downward movement of the expander device 16 should
2 only be stopped once a sufficient length of tubular
3 12 has been expanded to provide a sufficient anchor.

4
5 It should also be noted that the expandable portion
6 is no longer required to anchor the tubular 12 to the
7 borehole as the portions of the tubular 12 that have
8 been expanded by movement of the apparatus 10 secures
9 the tubular 12 to the casing 14. The friction and/or
10 sealing material (where used) can help to provide a
11 reliable anchor for the tubular 12 whilst it is being
12 expanded and also when in use.

13
14 As a further alternative, the inflatable device 28
15 can be releasably attached to the upper end 12u of
16 the tubular 12 before the apparatus 10 is run into
17 the borehole. The expansion cone 16 is located
18 within the upper end 12u of the tubular 12, the upper
19 end 12u being pre-expanded to accommodate the
20 expansion cone 16. Similar to the previous
21 embodiment, the inflatable device 28 has the
22 expansion cone 16 releasably coupled thereto via a
23 suitable coupling. Otherwise, the inflatable device
24 28 and the expansion cone 16 are substantially the
25 same as the previous embodiments.

26
27 The inflatable device 28 is inflated to expand the
28 inflatable annular balloon-type portion. As the
29 balloon-type portion expands, it contacts the tubular
30 12, thus providing an anchor between the tubular 12
31 and the casing 14. This contact between the balloon-

1 type portion and the casing 14 provides an anchor
2 point and/or a seal between the tubular 12 and the
3 casing 14. The seal is thus used to provide a sealed
4 fluid chamber for movement of the apparatus 10.

5
6 It should be noted that in this embodiment, the
7 forces applied to the tubular 12 by subsequent
8 movement of it, that is by pushing or pulling on the
9 tubular 12 for example, will be transferred to the
10 casing 14 via the inflatable device 28. However,
11 unlike conventional slips, the inflated balloon-type
12 portion is less likely to damage the casing 14.
13 Additionally, the size of the balloon-type portion
14 can be chosen whereby it is sufficiently large so as
15 not to lose its grip on the casing 14, even when the
16 inflatable device 28 is moved upwardly or downwardly.

17
18 As the expansion cone 16 moves downwards through the
19 tubular 12 to expand it, the movement thereof is
20 stopped after a predetermined time or distance, at
21 which point the expansion cone 16 is raised until the
22 coupling between the expansion cone 16 and the
23 inflatable device 28 latches. As with the previous
24 embodiment, the inflatable balloon-type portion can
25 be automatically deflated and further downward
26 movement of the expansion cone 16 causes the
27 inflatable device 28 also to move downward therewith.
28 It should be noted that the downward movement of the
29 expansion cone 16 should only be stopped once a
30 sufficient length of tubular 12 has been expanded to
31 provide a sufficient anchor.

1
2 The inflatable device 28 is not essential as a seal
3 is created at the surface by the rams of a blow-out
4 preventer (BOP) closing over the drill pipe,
5 electrical cable or umbilical to provide a fluid
6 chamber above the cone 16. However, a local seal can
7 be provided (e.g. the inflatable device 28).

8
9 Referring now to Fig. 2, there is shown the apparatus
10 10 in-use. It will be noted that the inflatable
11 device has been inflated to fully expand the pre-
12 expanded portion 12e into contact with the casing 14.
13 The pre-expanded portion 12e is typically provided
14 with a friction and/or sealing material (e.g.
15 materials 100, 122 in Figs 3 and 4) so that a seal
16 and/or anchor is created between the tubular 12 and
17 the casing 14.

18
19 The pump 18 draws fluid from below the cone 16 to
20 above it (as indicated by arrow 22), and the pressure
21 differential across the cone 16 causes it to move
22 downward and thereby radially expand the tubular 12.

23
24 It will be appreciated that the turbine 24 can be
25 integral with the cone 16, or can be provided above
26 or below it to draw fluids from above or below the
27 cone 16 by way of the pump 18.

28
29 The apparatus 10 has the advantage that it avoids
30 "squeeze" problems. Conventional top-down methods
31 are generally hydraulic where fluid is pumped onto an

1 upper face of the cone at pressure, forcing the cone
2 to move downwards through the tubular to expand it.
3 However, this causes the formation or payzone to be
4 squeezed where movement of the cone downwardly in the
5 conventional method forces the fluids therebelow back
6 into the formation or payzone. This is because a
7 borehole is typically a blind bore (i.e. it is closed
8 at an end thereof that is typically near the
9 formation or payzone). The fluids are thus forced
10 into the formation or payzone and can cause
11 significant damage and can possibly fracture the
12 formation. The break up of the formation can
13 seriously affect productivity therefrom and is thus
14 undesirable.

15
16 The squeeze effect can also cause the cone to stop
17 because the fluids below the cone may become trapped
18 and thus a build up of pressure would occur beneath
19 the cone. As the pressure below the cone increases,
20 the hydraulic pressure above the cone that drives it
21 through the tubular must also be increased.

22
23 However, the apparatus 10 draws fluids from below the
24 cone 16 to above it and thus avoids the squeeze
25 problems by removing the fluid below the cone. This
26 is a significant advantage of the present invention.

27
28 It will be appreciated that the pressure differential
29 across the cone 16 may be quite large, and will
30 generally be sufficient to start expansion (i.e.
31 provide sufficient force to move the expansion cone

1 16 downwards and thus expand the tubular 12).
2 However, the reduction on pressure below the cone 16
3 is preferably kept to a minimum and will thus be
4 relatively small. This is because it is undesirable
5 for the pump 18 to draw up too much fluid because it
6 is undesirable to draw fluids and sand etc from the
7 formation or payzone.

8
9 Embodiments of the present invention thus provide
10 advantages in that there is provided a method of
11 expanding a tubular that works from the top down.
12 This has advantages in that if the apparatus 10
13 becomes stuck due to restrictions or protrusions in
14 its path, it is relatively simple to retrieve the
15 apparatus 10 from the borehole. This is because the
16 unexpanded portion of the tubular 12 is generally
17 below the apparatus 10, and thus the restricted
18 diameter of the unexpanded tubular does not make it
19 difficult to pull the apparatus 10 out of the
20 borehole.

21
22 Also, embodiments of the apparatus 10 draw fluids
23 from below the cone 16 to above it, and thus avoid
24 squeezing the formation or payzone, thus providing
25 significant advantages over conventional top-down
26 expansion methods.

27
28 Embodiments of the present invention also provide
29 advantages in that less equipment is required. There
30 is also no requirement to have a blind bore.

31

- 1 Modifications and improvements may be made to the
- 2 foregoing without departing from the scope of the
- 3 present invention.

1 CLAIMS

2

3 1. Apparatus for radially expanding a tubular
4 member, the apparatus (10, 200) comprising an
5 expander device (16, 216) and a drive means (18, 24,
6 218) for the expander device (16, 216), the drive
7 means (18, 24, 218) being capable of moving with the
8 expander device (16, 216).

9

10 2. Apparatus according claim 1, wherein the drive
11 means (18, 24, 218) is attached to the expander
12 device (16, 216).

13

14 3. Apparatus according to any preceding claim,
15 wherein the drive means (218) is integral with the
16 expander device (216).

17

18 4. Apparatus according to claim 3, wherein the
19 expander device (216) is provided with a
20 longitudinal throughbore (217) in which the drive
21 means (218) is located.

22

23 5. Apparatus according to any preceding claim,
24 wherein the drive means comprises a pump (18, 218).

25

26 6. Apparatus according to claim 5, wherein the
27 pump (18, 218) creates a differential pressure
28 across the expansion cone (16, 216).

29

30 7. Apparatus for radially expanding a tubular
31 member, the apparatus comprising an expander device
32 (16, 216) and a drive means (18, 24, 218) for the

1 expander device (16, 216), the drive means (18, 24,
2 218) being capable of entering the tubular member
3 (12) and moving the expander device (16, 216).
4

5 8. Apparatus according to claim 7, wherein the
6 drive means (18, 24, 218) is attached to the
7 expander device (16, 216).
8

9 9. Apparatus according to claim 7 or claim 8,
10 wherein the drive means (218) is integral with the
11 expansion cone (216).
12

13 10. Apparatus according to claim 9, wherein the
14 expansion cone (216) is provided with a longitudinal
15 throughbore (217) in which the drive means (218) is
16 located.
17

18 11. Apparatus according to any one of claims 7 to
19 10, wherein the drive means comprises a pump (18,
20 218).
21

22 12. Apparatus according to claim 11, wherein the
23 pump (18, 218) creates a differential pressure
24 across the expansion cone (16, 216).
25

26 13. Apparatus for expanding a tubular member,
27 comprising an expander device (216) having an
28 integral drive means (218) for moving the device
29 (216) within the tubular member (12).
30

31 14. Apparatus according to claim 13, wherein the
32 expander device (216) is provided with a

1 longitudinal throughbore (217) in which the drive
2 means (218) is located.

3

4 15. Apparatus according to claim 13 or claim 14,
5 wherein the drive means comprises a pump (218).

6

7 16. Apparatus according to claim 15, wherein the
8 pump (218) creates a differential pressure across
9 the expander device (216).

10

11 17. A method of radially expanding a tubular
12 member, the method comprising the steps of providing
13 an expander device (16, 216) and a drive means (18,
14 24, 218), locating the device (16, 216) and drive
15 means (18, 24, 218) in the tubular member (12), and
16 actuating the drive means (18, 24, 218) to radially
17 expand the member (12).

18

19 18. A method according to claim 17, wherein the
20 method includes the additional step of locating the
21 tubular member (12) in a second conduit (14).

22

23 19. A method according to claim 17 or claim 18,
24 wherein the method includes the additional step of
25 temporarily anchoring an end of the tubular member
26 (12).

27

28 20. A method according to any one of claims 17 to
29 19, wherein the drive means comprises a pump (18,
30 218).

31

1 21. A method according to claim 20, wherein the
2 step of actuating the drive means comprises applying
3 power to the pump (18, 218).
4

5 22. A method according to any one of claims 17 to
6 21, wherein the method includes the additional step
7 of attaching the drive means (18, 24, 218) to the
8 expansion cone (16, 216).
9

10 23. A method according to any one of claims 17 to
11 22, wherein the method includes the additional step
12 of providing the drive means (218) integral with the
13 expander device (216).
14

15 24. A method according to any one of claims 17 to
16 23, wherein the method includes the additional step
17 of creating a differential pressure across the
18 expander device (16, 216).
19

20 25. A method according to claim 24, wherein the
21 method includes the additional step of drawing fluid
22 from one side of the expansion cone (16, 216) to the
23 other.
24

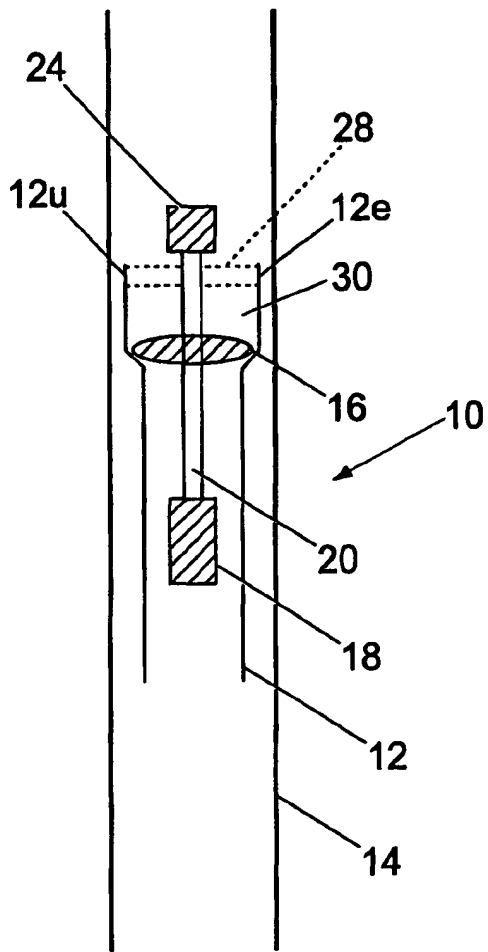

Fig. 1

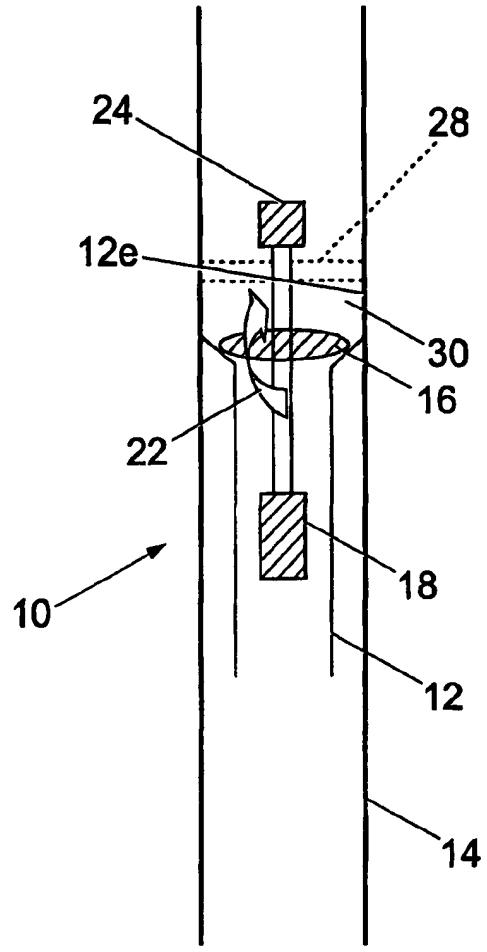
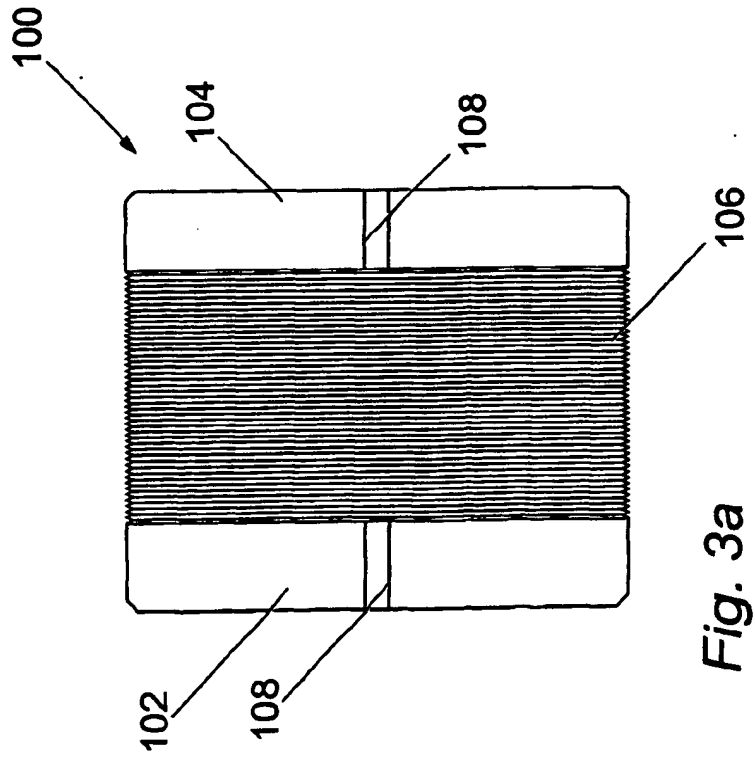
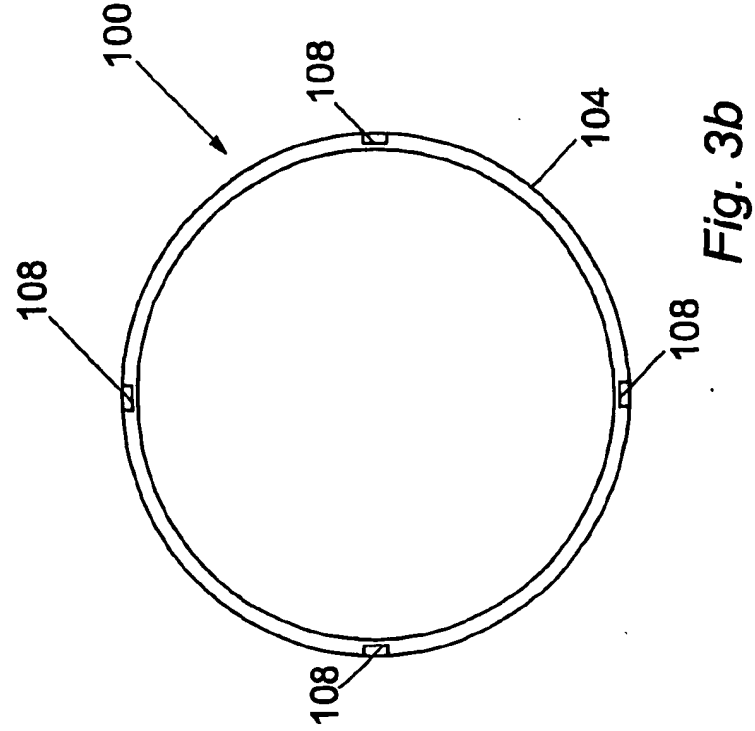
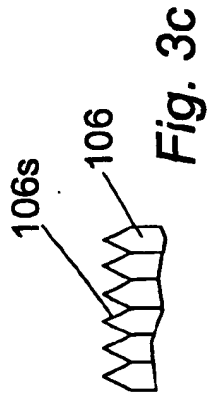

Fig. 2



3/4

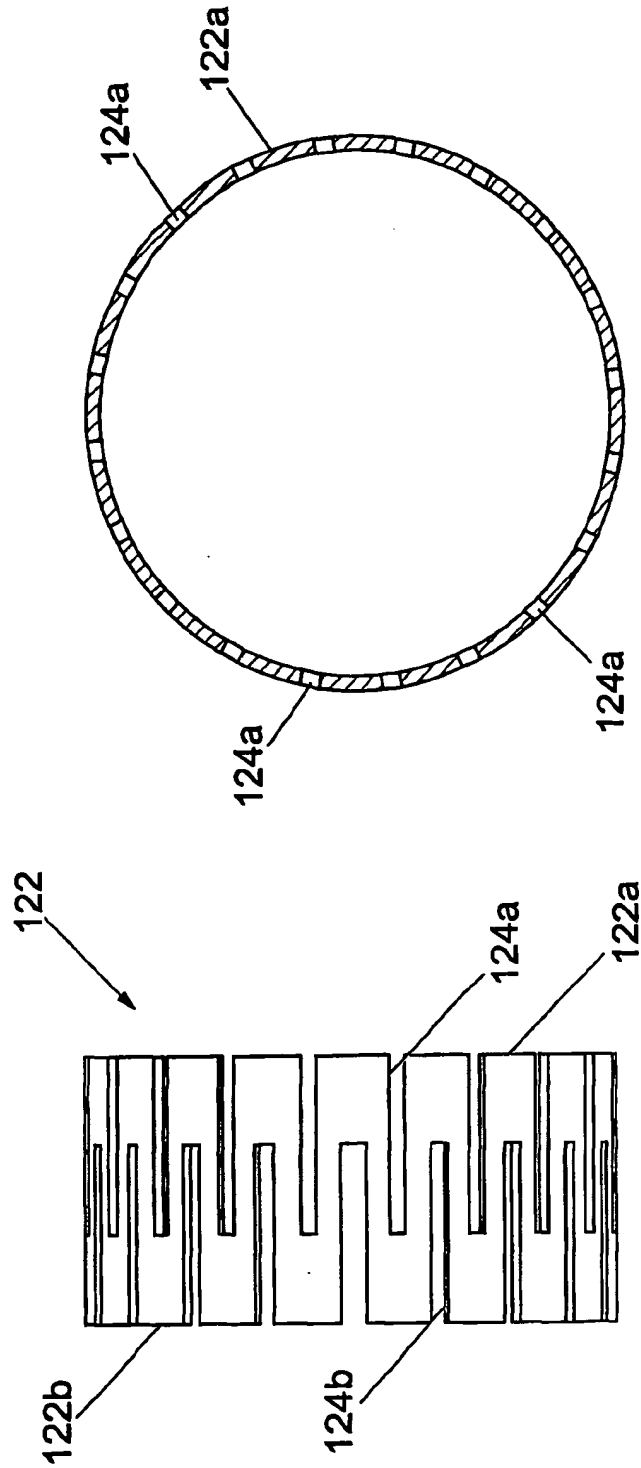

Fig. 4a

Fig. 4b

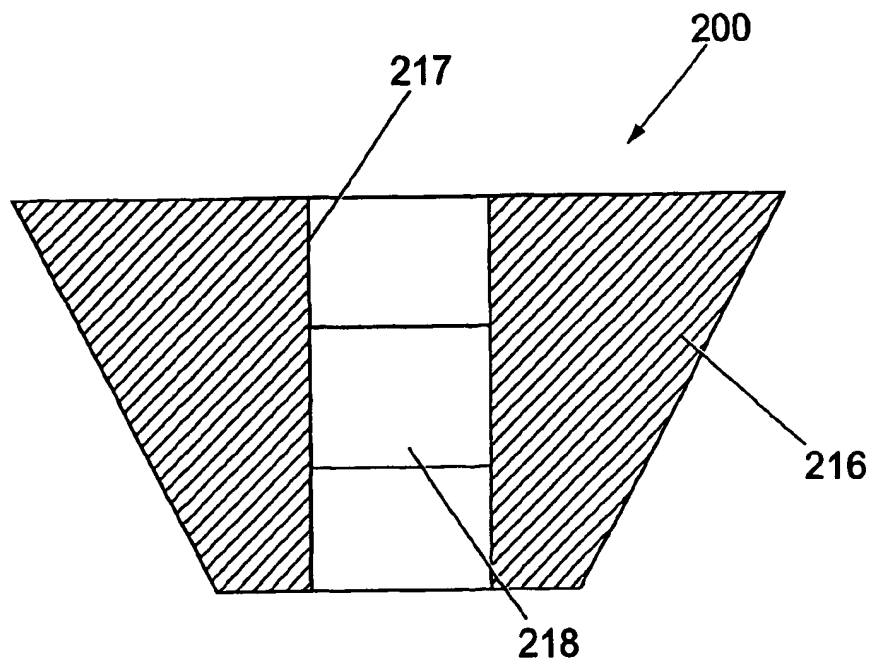

Fig. 5

INTERNATIONAL SEARCH REPORT

International Application No
P. 1/68 02/02171

A. CLASSIFICATION OF SUBJECT MATTER
IPC 7 E21B43/10 E21B4/00

According to International Patent Classification (IPC) or to both national classification and IPC

B. FIELDS SEARCHED

Minimum documentation searched (classification system followed by classification symbols)
IPC 7 E21B

Documentation searched other than minimum documentation to the extent that such documents are included in the fields searched

Electronic data base consulted during the international search (name of data base and, where practical, search terms used)

EPO-Internal

C. DOCUMENTS CONSIDERED TO BE RELEVANT

Category *	Citation of document, with indication, where appropriate, of the relevant passages	Relevant to claim No.
X	US 3 203 483 A (VINCENT RENIC P) 31 August 1965 (1965-08-31) column 5, line 45 -column 7, line 4; figures 7-10	1-25
X	WO 00 37766 A (ASTEC DEV LTD ;SIMPSON NEIL ANDREW ABERCROMBI (GB)) 29 June 2000 (2000-06-29) page 26, line 17 -page 27, line 9; figure 19 page 34, line 20 -page 38, line 12; claim 28; figures 27-30	1-5, 7-11, 13-25
P,X	WO 01 33037 A (STEWART R BRUCE ;COOK ROBERT LANCE (US); COWAN KENNETH MICHAEL (US) 10 May 2001 (2001-05-10) page 34, line 24 -page 36, line 18; figure 3	1-25

Further documents are listed in the continuation of box C.

Patent family members are listed in annex.

* Special categories of cited documents:

- 'A' document defining the general state of the art which is not considered to be of particular relevance
- 'E' earlier document but published on or after the international filing date
- 'L' document which may throw doubts on priority claim(s) or which is cited to establish the publication date of another citation or other special reason (as specified)
- 'O' document referring to an oral disclosure, use, exhibition or other means
- 'P' document published prior to the international filing date but later than the priority date claimed

- 'T' later document published after the international filing date or priority date and not in conflict with the application but cited to understand the principle or theory underlying the invention
- 'X' document of particular relevance; the claimed invention cannot be considered novel or cannot be considered to involve an inventive step when the document is taken alone
- 'Y' document of particular relevance; the claimed invention cannot be considered to involve an inventive step when the document is combined with one or more other such documents, such combination being obvious to a person skilled in the art.
- '&' document member of the same patent family

Date of the actual completion of the international search

6 August 2002

Date of mailing of the international search report

14/08/2002

Name and mailing address of the ISA
European Patent Office, P.B. 5818 Patentlaan 2
NL - 2280 HV Rijswijk
Tel. (+31-70) 340-2040, Tx. 31 651 epo nl,
Fax (+31-70) 340-3016

Authorized officer

van Berlo, A

INTERNATIONAL SEARCH REPORT

International Application No
PCT/GB 02/02171

C.(Continuation) DOCUMENTS CONSIDERED TO BE RELEVANT		
Category *	Citation of document, with indication, where appropriate, of the relevant passages	Relevant to claim No.
P,X	US 2001/045284 A1 (SIMPSON NEIL A A ET AL) 29 November 2001 (2001-11-29) figures 6-8	1-5, 7-11, 13-16, 18-23
A	WO 01 18355 A (DUCASSE CHRISTOPHER ;E2TECH LTD (GB); OOSTERLING PETER (NL)) 15 March 2001 (2001-03-15) page 10, line 23 -page 11, line 26	1,7,13, 17
A	US 3 245 471 A (HOWARD GEORGE C) 12 April 1966 (1966-04-12) column 5, line 29-64; figures 1,2	1
A	WO 99 35368 A (SHELL CANADA LTD ;SHELL INT RESEARCH (NL)) 15 July 1999 (1999-07-15) figure 4	1

INTERNATIONAL SEARCH REPORT

Information on patent family members

International Application No
PCT/GB 02/02171

Patent document cited in search report	Publication date	Patent family member(s)	Publication date	
US 3203483	A	31-08-1965	US 3179168 A US 3203451 A	20-04-1965 31-08-1965
WO 0037766	A	29-06-2000	AU 1867900 A AU 1868700 A AU 1868800 A AU 1868900 A AU 1876600 A AU 1876800 A EP 1147287 A2 EP 1141517 A1 EP 1141515 A1 EP 1144802 A2 EP 1151180 A1 EP 1141518 A1 WO 0037766 A2 WO 0037771 A1 WO 0037768 A1 WO 0037767 A2 WO 0037772 A1 WO 0037773 A1 GB 2345308 A GB 2346632 A GB 2346400 A GB 2346909 A GB 2347445 A NO 20012596 A NO 20012597 A NO 20012598 A NO 20012599 A NO 20012600 A NO 20012865 A US 2002079106 A1 US 2002060079 A1	12-07-2000 12-07-2000 12-07-2000 12-07-2000 12-07-2000 12-07-2000 24-10-2001 10-10-2001 10-10-2001 17-10-2001 07-11-2001 10-10-2001 29-06-2000 29-06-2000 29-06-2000 29-06-2000 29-06-2000 29-06-2000 05-07-2000 16-08-2000 09-08-2000 23-08-2000 06-09-2000 27-07-2001 27-07-2001 30-07-2001 30-07-2001 30-07-2001 07-08-2001 27-06-2002 23-05-2002
WO 0133037	A	10-05-2001	AU 1356601 A WO 0133037 A1	14-05-2001 10-05-2001
US 2001045284	A1	29-11-2001	US 6325148 B1 US 2002079100 A1 AU 1044201 A WO 0146551 A1	04-12-2001 27-06-2002 03-07-2001 28-06-2001
WO 0118355	A	15-03-2001	AU 7021100 A EP 1210503 A1 WO 0118355 A1 NO 20021082 A	10-04-2001 05-06-2002 15-03-2001 13-03-2002
US 3245471	A	12-04-1966	NONE	
WO 9935368	A	15-07-1999	AU 740213 B2 AU 2418699 A BR 9814563 A CA 2316978 A1 WO 9935368 A1 EP 1044316 A1 JP 2002500306 T NO 20003402 A	01-11-2001 26-07-1999 17-10-2000 15-07-1999 15-07-1999 18-10-2000 08-01-2002 25-08-2000